

INDUSTRIAL ROTATOR **GIR12, GIR12-01**

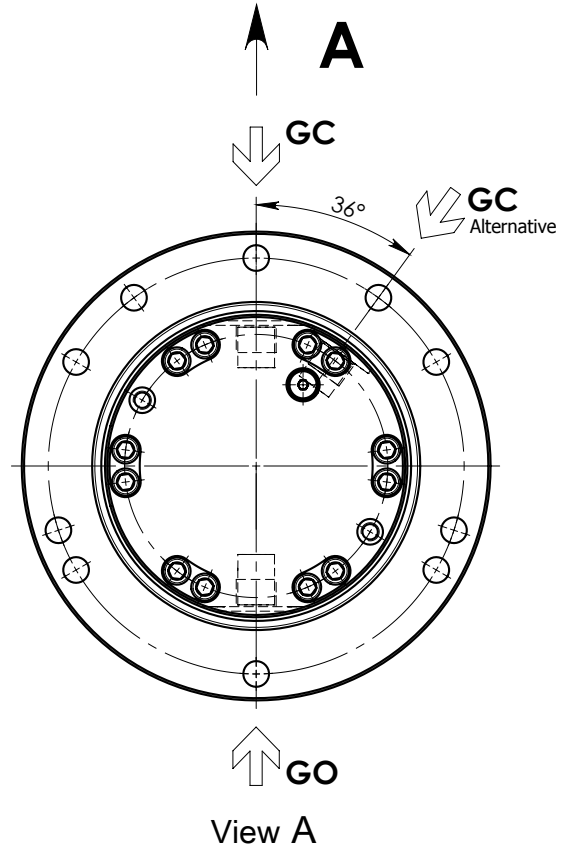
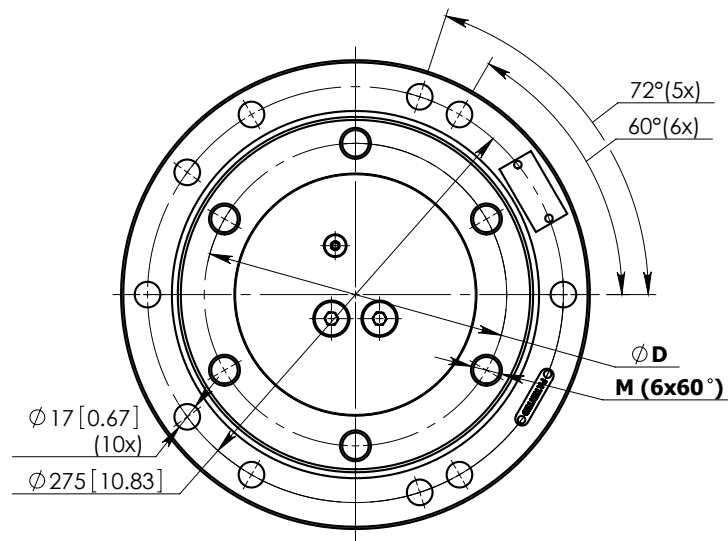
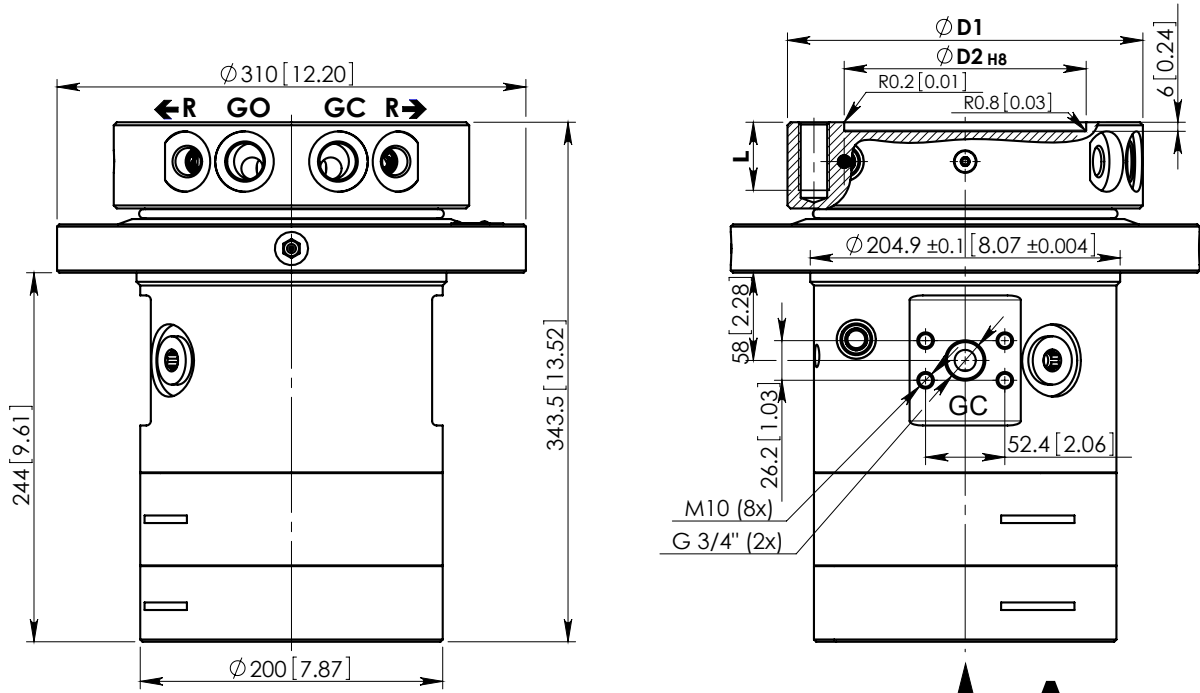

Technical data

Rotation	Unlimited
Max axial load static	± 250 KN [56202 lbf]
Max axial load dynamic	± 80 KN [17985 lbf]
Torque at 20 Mpa	2000 Nm [1475 lb ft]
Rated displacement	724 cm ³ /rev. [44.2 in ³ /rev.]
Rotation speed	max 30 rpm
Oil duct area for grapple	150 mm ² [0.232in ²]

	D	D1	D2	M	L	Weight
GIR 12-00	200 [7.87]	235 [9.25]	160 [6.3]	M20	45 [1.77]	85 kg [188 lb]
GIR 12-01	180 [7.09]	210 [8.27]	140 [5.51]	M16	40 [1.57]	82 kg [180 lb]

Function	Max working pressure	Rec oilflow	Connection
R - rotation	21 MPa [3045 psi]*	25 l/min [6.6 gal(US)/min]	G 1/2"
GO - grapple/tool open	32 MPa [4640 psi]*		G 3/4", SAE 1"
GC - grapple/tool close	32 MPa [4640 psi]*		G 3/4", SAE 1"

* Relief valves fitted