

# ROTATOR GIR 25

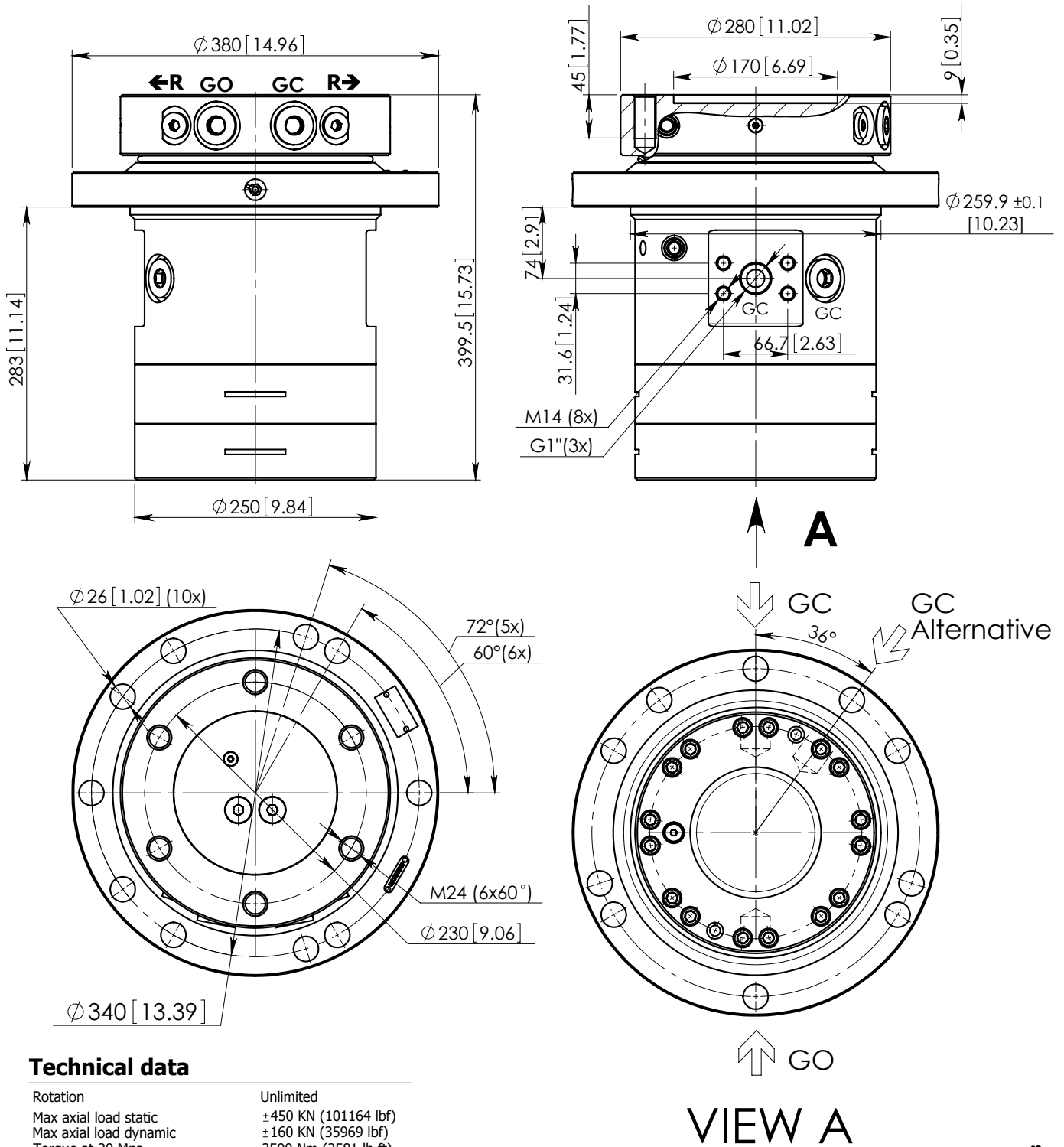

## Technical data

Rotation	Unlimited
Max axial load static	±450 kN (101164 lbf)
Max axial load dynamic	±160 kN (35969 lbf)
Torque at 20 Mpa	3500 Nm (2581 lb ft)
Rated displacement	1304 cm <sup>3</sup> /rev
Rotation speed	max 25 rpm
Oil duct area for grapple	260 mm <sup>2</sup> (0.403 in <sup>2</sup> )
Weight	146 kg (322 lb)

Function	Max working pressure	Rec oilflow	Connections
<b>R</b> - rotation	21 MPa (3045 psi)*	35l/min	G 1/2"
<b>GO</b> - grapple/tool open	32 MPa (4641 psi)*		G 1", SAE 1 1/4"
<b>GC</b> - grapple/tool close	32 MPa (4641 psi)*		G 1", SAE 1 1/4"

\* Relief valve fitted